

Product Ordering Information

Flexco® Belt Maintenance Tools Belt Lifters

Flex-Lifter™ Conveyor Belt Lifter

Easy and safe way to lift tensioned belts so mechanical splicing or other maintenance work can be done.

DESCRIPTION	ORDERING NUMBER	ITEM CODE	WT. LBS.
Medium Flex-Lifter 36" - 60" (900 - 1500 mm) incl. return bar	FL-M	76469	91.0
Large Flex-Lifter 48" - 72" (1200 - 1800 mm) incl. return bar	FL-L	76470	128.0
XL Flex-Lifter 72" - 96" (1800 - 2400 mm) does not incl. return bar	FL-XL	76983	128.0
Flex-Lifter Cart	FLCK	77729	20.0

Lifts troughed or flat belts.
Lead time: 1 working day

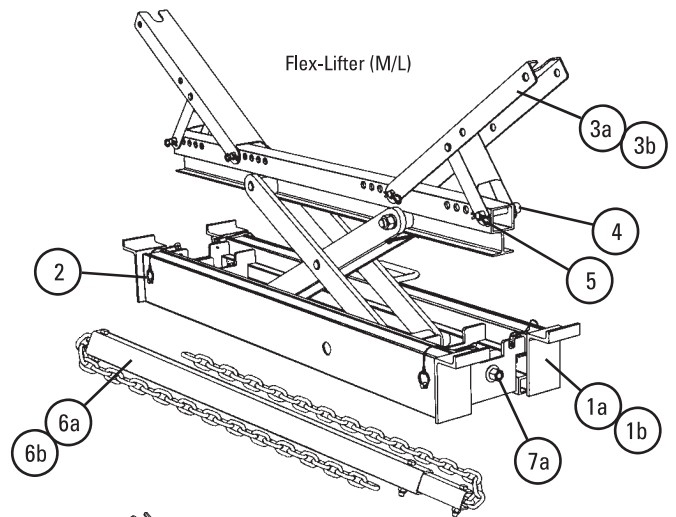

Replacement Parts

REF	DESCRIPTION	ORDERING NUMBER	ITEM CODE	WT. LBS.
1a	Extension Leg - Medium	FLEL-M	76472	3.1
1b	Extension Leg - Large	FLEL-L	76473	3.7
1c	Extension Leg Kit- XL (includes 2 ext. legs)	FLELK-XL	76986	13.0
2	Extension Leg Pin (with lanyard)	FLELP	76474	0.1
3a	Trough Wing - Medium (with brace)	FLTW-M	76476	1.2
3b	Trough Wing - Large (with brace)	FLTW-L	76477	1.5
3c	Trough Wing - XL (with brace)	FLTW-XL	76985	4.2
4	Retainer Pin Pack (includes 4 pins)	FLRP	76478	1.0
5	Retainer Clip Pack (includes 4 clips)	FLCP	76479	0.1
6a	Return Lift Bar - Medium	FLRLB-M	76482	25.0
6b	Return Lift Bar - Large	FLRLB-L	76481	50.0
6c	V-Return Lift Bar - XL	FLVRL-XL	76984	63.0
7a	Shear Pin Kits - Medium/Large	FL-PKIT-ML	77250	0.3
7b	Shear Pin Kits - XL	FL-PKIT-XL	77251	0.5

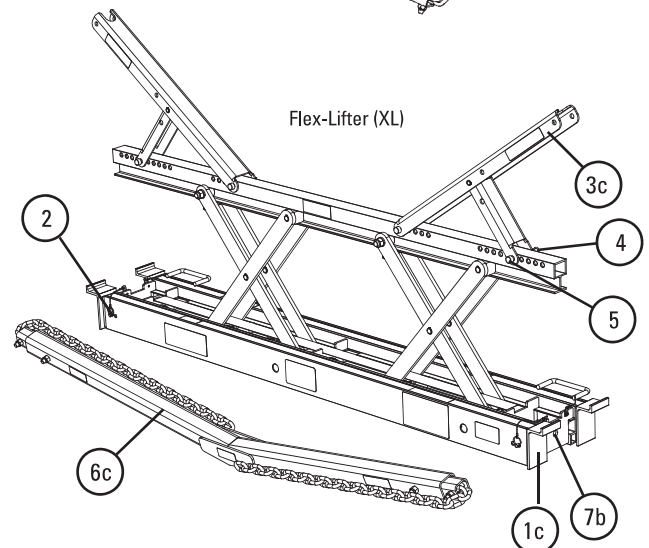

Safe Lifting Capacity

Height		Max. Weight			
		Medium/Large		XL	
in.	mm	lbs.	kg.	lbs.	kg.
0-1	0-25	500	225	1100	500
1-2	25-50	1000	450	1800	815
2-3	50-75	1500	675	2500	1140
3-4	75-100	2000	900	3200	1450
4-5	100-125	2500	1150	3700	1680
5-6	125-150	3000	1350	4600	2090
6-7	150-175	3500	1600	5300	2400
>7	>175	4000	1800	6000	2725

Aluminum Content Flex-Lifter

ALUMINUM ALLOY TYPE	PERCENT	
	Mg Magnesium	Ti Titanium
4043	0.05%	0.2%
5356	5.5%	0.2%
6005	0.6%	0.1%
6061	1.0%	0.0%
6063	0.7%	0.0%
7075	2.5%	0.0%

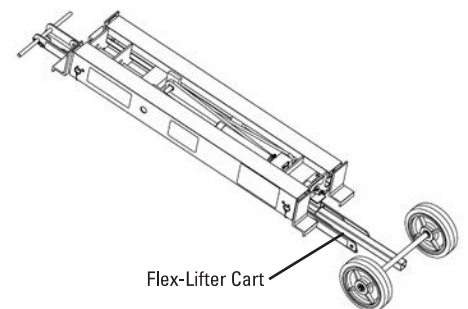

U.S. Patent No. 7,810,788

Product Ordering Information

Flexco® Belt Maintenance Tools Belt Cutters and Clamps

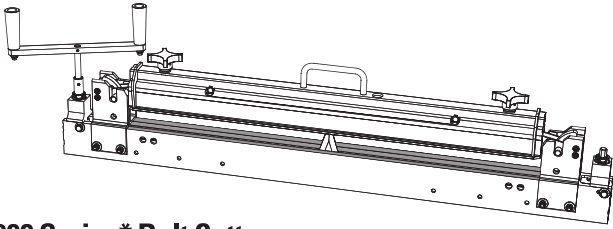

900 Series* Belt Cutter

DESCRIPTION	BELT WIDTH		ORDERING NUMBER	ITEM CODE	WT. LBS.
	in.	mm			
Cutter Complete for belts up to 1.5" (38 mm) * Patent Pending	24	600	900924	04200	34.0
	36	900	900936	04143	39.4
	48	1200	900948	04144	48.0
	60	1500	900960	04145	54.0
	72	1800	900972	04146	60.3
Replacement Blade Kit			900CBK	04149	0.15
Drive Handle Assembly				04140	2.0

Lead time: 1 working day

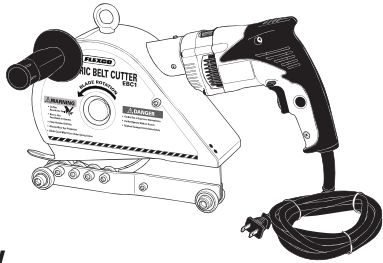

Cutting Capacity

BELT TYPE	EBC1/CEBC1		EBC2/CEBC2	
	Imperial	Metric	Imperial	Metric
Rubber	Up to 1"	Up to 25 mm	Up to 2"	Up to 50 mm
PVC	Up to 360 PIW	Up to 630 EP	Up to 1140 PIW	Up to 2000 EP

Far-Pul™ HD® Belt Clamps

Load Capacity up to 3 tons (2.7 metric tons) when used with two 1-1/2 ton (1.4 metric ton) come-alongs.

DESCRIPTION	BELT WIDTH		ORDERING NUMBER	ITEM CODE	WT. LBS.
	in.	mm			
Belt Clamp Complete includes: 4 Belt Clamp Bars and 4 Belt Clamp Scissors	Up to 30	Up to 750	LSHD30	30393	79.0
	Up to 36	Up to 900	LSHD36	30394	87.0
	Up to 42	Up to 1050	LSHD42	30395	91.0
	Up to 48	Up to 1200	LSHD48	30396	98.0
	Up to 54	Up to 1350	LSHD54	30397	103.0
	Up to 60	Up to 1500	LSHD60	30398	110.0
	Up to 72	Up to 1800	LSHD72	30399	121.0
30" Belt Clamp Bar Set*	Up to 30	Up to 750	LSHDB30-2	30418	20.0
36" Belt Clamp Bar Set*	Up to 36	Up to 900	LSHDB36-2	30414	23.0
42" Belt Clamp Bar Set*	Up to 42	Up to 1050	LSHDB42-2	30421	26.0
48" Belt Clamp Bar Set*	Up to 48	Up to 1200	LSHDB48-2	30423	30.0
54" Belt Clamp Bar Set*	Up to 54	Up to 1350	LSHDB54-2	30424	33.0
60" Belt Clamp Bar Set*	Up to 60	Up to 1500	LSHDB60-2	30430	36.0
72" Belt Clamp Bar Set*	Up to 72	Up to 1800	LSHDB72-2	30408	40.0
Steel Belt Clamp Scissor - Each			LSHDS	30392	10.5
Belt Locator Pin - includes Washer and Locking Nut			LSHDLP	30400	.15
Retaining Pin Kit			LSHD-RPK	30390	2.0
Clamp Bar Screw			LSHDCBS	30373	1.0

*Includes 2 Bars per Set
Lead time: 1 working day

Shaded items are made to order.
Lead time: 5 working days

Aluminum Content 900 Series Belt Cutter

ALUMINUM ALLOY TYPE	PERCENT	
	Mg Magnesium	Ti Titanium
6005	0.6%	0.1%
6061	1.0%	0.0%
7075	2.5%	0.0%

Electric Belt Cutter

DESCRIPTION	ORDERING NUMBER	ITEM CODE	WT. LBS.
Electric Belt Cutter (for belts up to 1" thick)	EBC1	30001	29.5
Electric Belt Cutter (for belts up to 2" thick)	EBC2	30002	40.0
Replacement Blade for EBC1	EBC1-B	30003	2.0
Replacement Blade for EBC2	EBC2-B	30004	2.8
Replacement Electric Hammer Drill for EBC1	EBC1-DR	30005	7.5
Replacement Electric Hammer Drill for EBC2	EBC2-DR	30006	12.1
Replacement Eyebolt for EBC1 & EBC2	EBC-EB	30007	.9
Replacement Handle for EBC1 & EBC2	EBC-H	30008	.4

Cordless Electric Belt Cutter

DESCRIPTION	ORDERING NUMBER	ITEM CODE	WT. LBS.
Cordless Electric Belt Cutter (for belts up to 1" thick)	CEBC1	30018	29.0
Cordless Electric Belt Cutter (for belts up to 2" thick)	CEBC2	30019	39.5

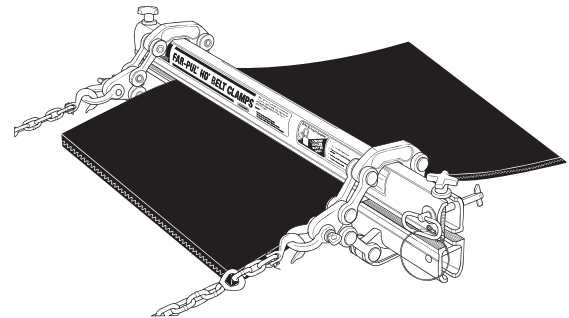

Aluminum Content Far-Pul™ HD®

ALUMINUM ALLOY TYPE	PERCENT	
	Mg Magnesium	Ti Titanium
6061	1.0%	0.0%