

This range of tap wrenches are ideal for holding taps, reamers, screw extractors and other such small hand turned tools. All wrenches have a sliding T handle frictionally held, that allows these tap wrenches to be used even in confined spaces

These are available in two types:

**a. Regular T Handle Type -**

Self-centering hardened steel jaws provide a positive grip on taps, reamers and other such small tools

**b. Ratchet Type**

These tap wrenches have self centering hardened steel jaws and knurled chuck sleeve, which provide positive grip on taps, reamers and other such small tools. The ratchet can be set left or right, or direct engagement in neutral position. This feature allows them to be used in confined areas with ease

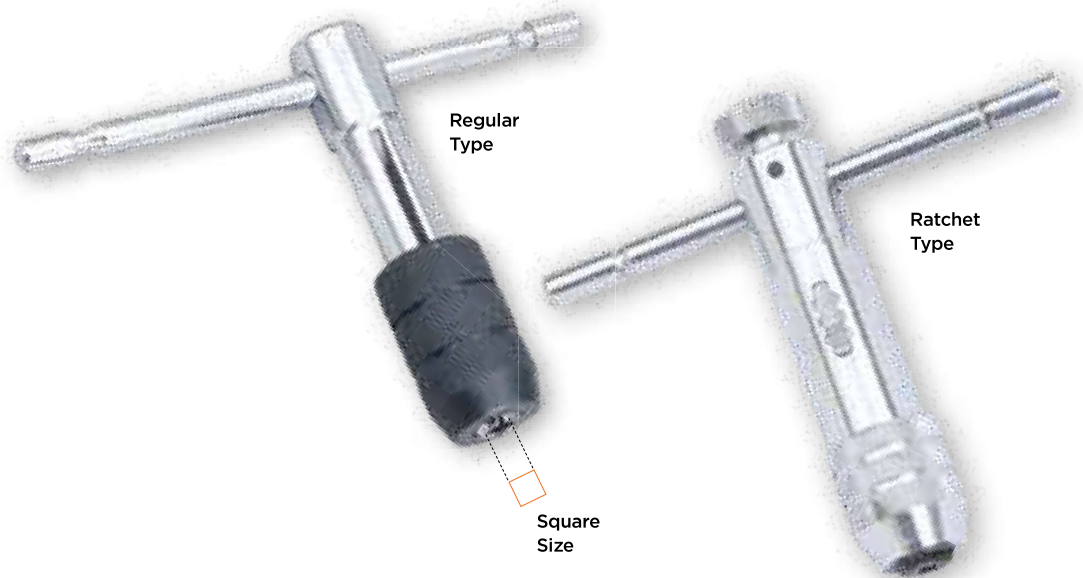

**ORDERING INFORMATION**

| CAT NR.             | OVERALL LENGTH (L) |      | JAW HOLDING CAPACITY |         |           |        | BOX QTY. |
|---------------------|--------------------|------|----------------------|---------|-----------|--------|----------|
|                     |                    |      | SQUARE SIZE          |         | TAP SIZE  |        |          |
|                     | (INCH)             | (MM) | (INCH)               | (MM)    | (INCH)    | (MM)   |          |
| <b>REGULAR</b>      |                    |      |                      |         |           |        |          |
| TW/3-16             | 2.23/64            | 60   | 5/64-5/32            | 2-4     | 1/16-3/16 | M2-M5  | 10       |
| TW/1-4/SPL          | 2.3/4              | 70   | 5/64-13/64           | 2-5     | 1/16-1/4  | M2-M6  | 10       |
| *TW/1-4             | 2.3/4              | 70   | 1/8-13/64            | 3.15-5  | 5/32-1/4  | M4-M6  | 10       |
| TW/5-16             | 3.9/64             | 80   | 5/32-1/4             | 4-6.3   | 3/16-5/16 | M5-M8  | 10       |
| *TW/1-2             | 3.35/64            | 90   | 13/64-5/16           | 5-8     | 1/4-1/2   | M6-M10 | 10       |
| <b>RATCHET TYPE</b> |                    |      |                      |         |           |        |          |
| *TW/R/1-4           | 3.3/8              | 86   | 7/64-7/32            | 2.6-5.5 | 5/32-1/4  | M4-M6  | 5        |
| *TW/R/5-16          | 4.3/8              | 111  | 3/16-5/16            | 4.6-8   | 1/4-1/2   | M6-M12 | 5        |

\* Best Seller